

**ELEBOR**<sup>®</sup>

**ELEBOR S.A.**

**HELLENIC GEOTECHNICAL EQUIPMENT**



Edition 2024

Catalogue

# Split-Type Friction Bolt Stabilizers

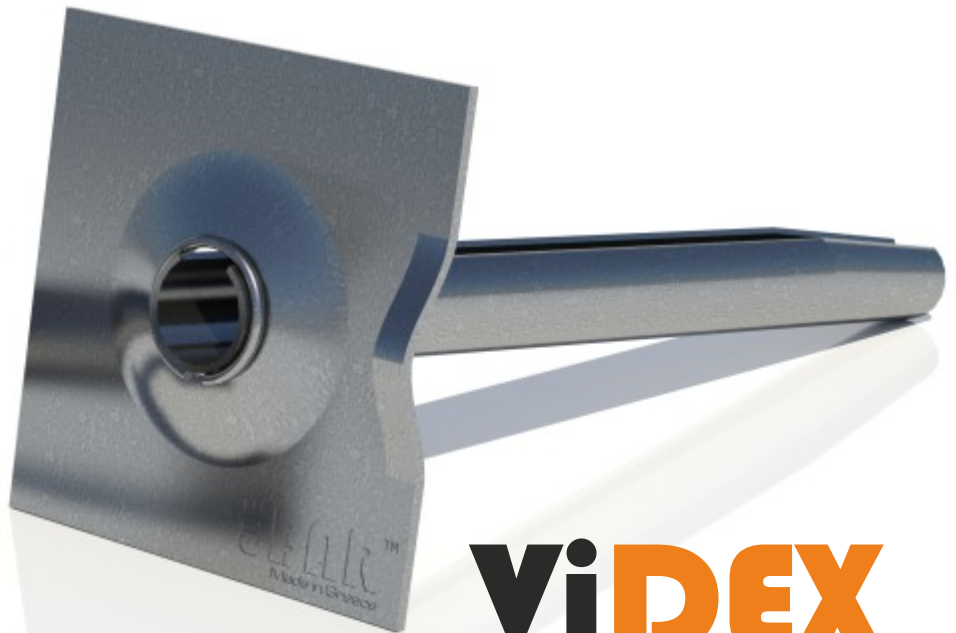

**ViDEX**

Boring - Drilling - Tunnelling - Mining - Construction - Geotechnical



# Introduction

The ViDEX™ stabilizers is a proven friction bolt system used for decades in mines all over the world.

The split-tubular body is produced from premium grade steel sheet on automated production lines.

Entire process from raw material arrival to finish product despatch or storing is monitored and controlled in respect of quality assurance and traceability.

System components and tools are designed and manufactured with the aid of the state-of-the-art three-dimensional (3D) parametric mechanical CAD/CAM software.

**a world-wide proven  
friction bolt system**

## System features - Advantages

ViDEX™ is a friction stabilizer that is activated when its tubular steel body is forced by percussion to fit inside a bore-hole that has a smaller diameter than the nominal diameter of the bolt.

Due to the use of a special spring grade steel and to the geometry of the body section, the ViDEX™ bolt is brought in true and tight contact with the borehole walls thus exerting radial forces to the surrounding rock/strata.

The main features and advantages of ViDEX™ split type friction bolts can be summarized as follows:

- ability to yield instead of failing
- full-length active support
- active radial and axial support
- loads rock in compression
- immediate support
- anchorage increases with time
- grip increases with rock shifts
- corrosion / oxidation add to the increase of support
- maintains support even if the bearing plate is knocked offé
- their performance has been proved by millions of installations and tests internationally
- fast and easy installation
- does not require any special equipment (apart from the drive tool)
- installation by all types of jackdrills and roof-bolting jumbos.
- visual inspection (check that slot width is visibly reduced)
- after installing does not require any supplementary actions such as torquing, retorquing, grouting etc.)
- simple design with minimal stress concentration
- maintains plate pressure
- effective support at any installation angle



**a fast, reliable and repeatable bolting system**

# Applications

## Tunneling

- radial and roof rock bolting,
- tunnel entrance preparation/support,
- slope stabilization,
- hanging & supporting suspended equipment (ventilation fans, ducts etc.)
- wire mesh fixing.

## Underground & Surface Mining

- radial and roof rock bolting (immediate support),
- hanging & supporting suspended equipment (ventilation fans, ducts, conveyor belts etc.)
- wire mesh fixing.

## Geotechnics

- slope/embankment stabilization,
- soil nailing,
- wire mesh fixing.

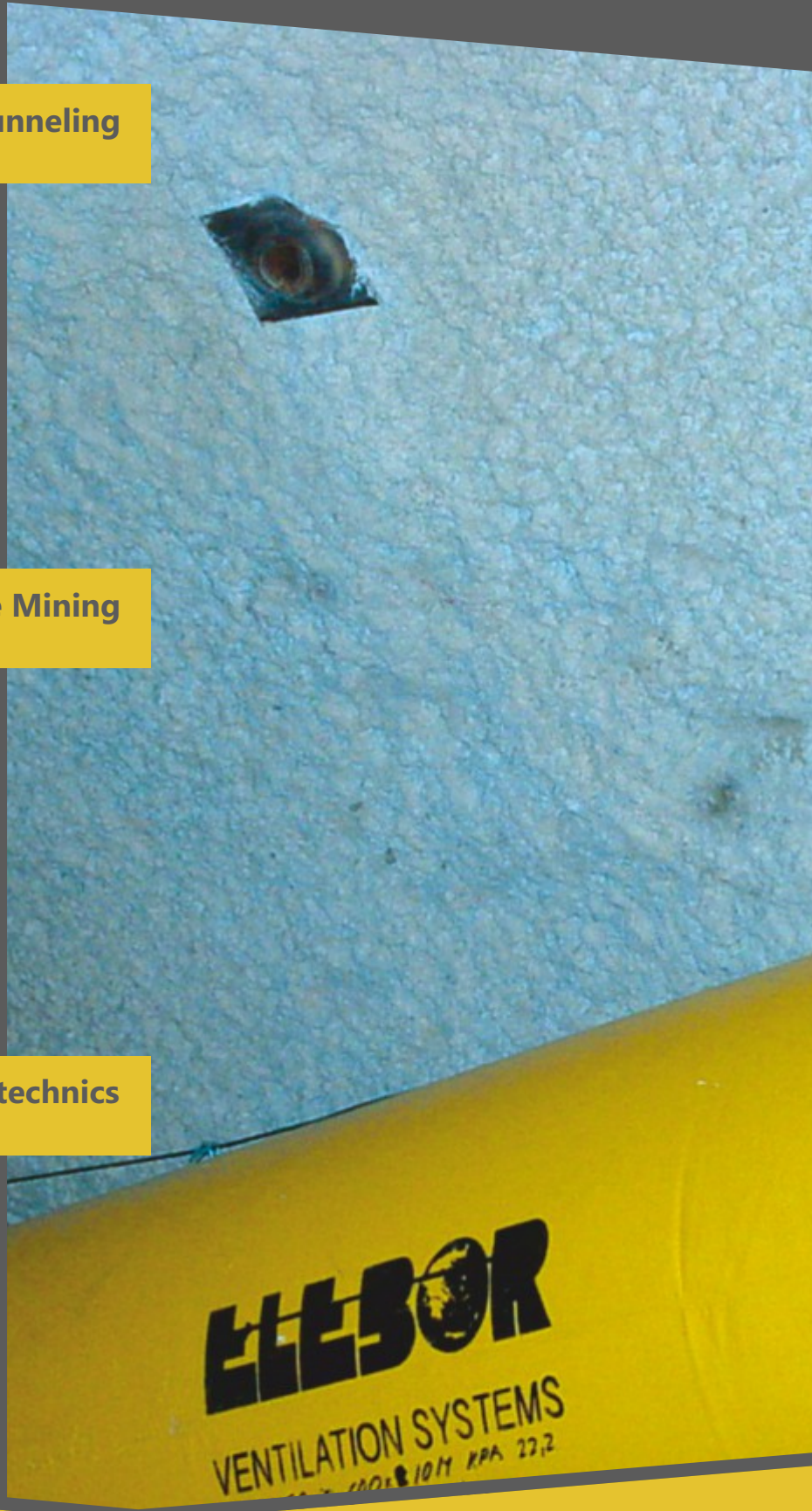

# Main system components

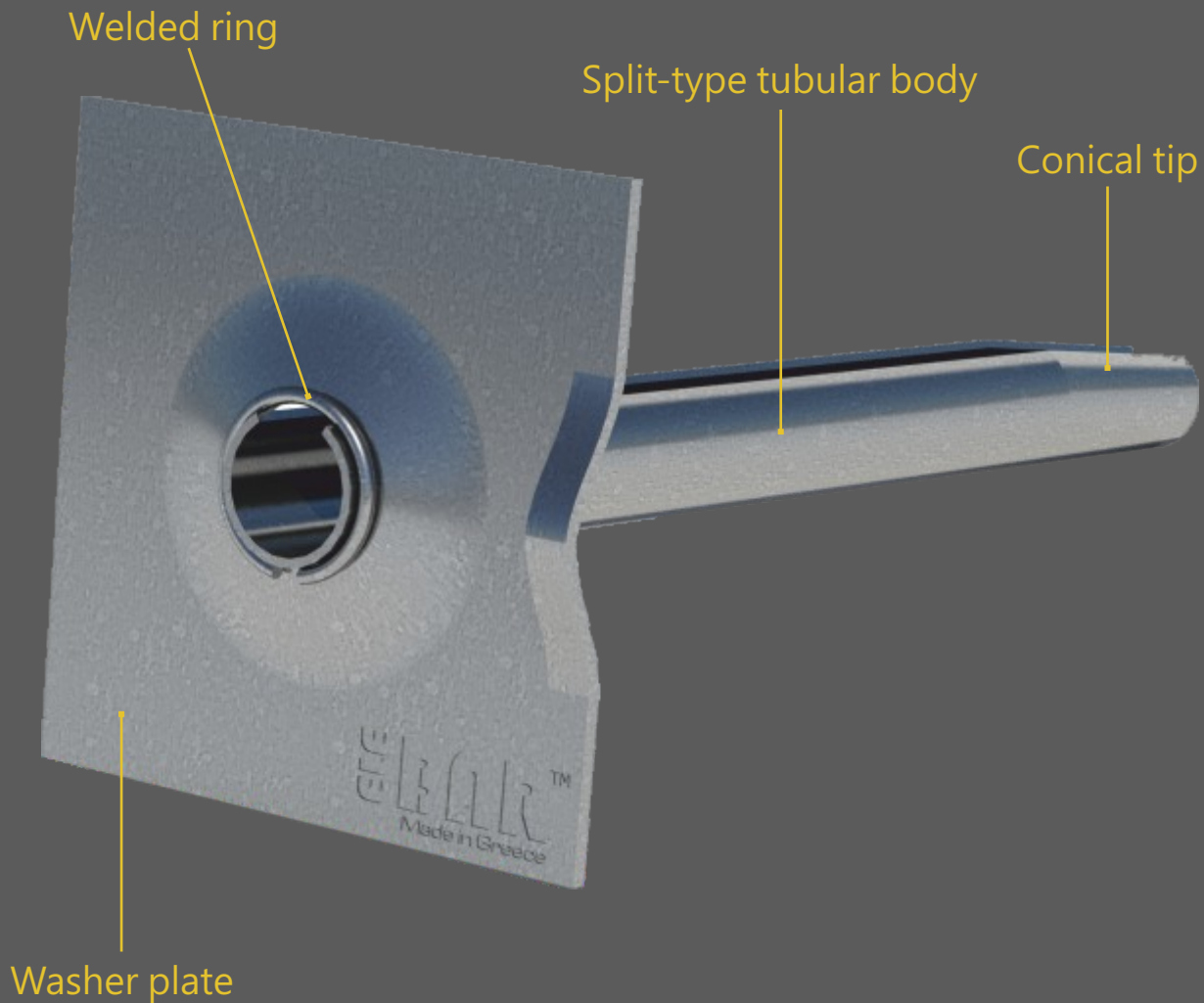

## Tubular Split Tube

The body of the VIDEX™ friction bolt is made from a high tensile steel sheet which is rolled into an open-loop C-shaped profile.

One end of the tubular split tube is press-formed into a slightly conical tip to aid insertion of the bolt into the drilled bore-hole, while the other end receives a mig welded C ring that serves a fixing element for the anchorage washer plate.

## Washer plate

Washer plates are typically made by S275JR steel sheet at varying sheet thicknesses and varying dimensions. Upon request washer plate at custom dimensions can be made.

Features like dog-ear can be made so that the Videx bolt can act additionally as an equipment suspension element.

# ViDEX™ technical specifications

The ViDEX™ friction bolts are made of a high-strength spring-quality steel. Five (5) models are available with external tube diameter of 33, 35, 39, 42 or 46 mm and in lengths ranging from 0.5 to 4.9 m in 0.3 increments. Other lengths are available on request.

Hot-dip galvanized versions are available on request for all models.

			VFB33	VFB35	VFB39	VFB42	VFB46
External diameter, nominal		mm	33	35	39	42	46
External diameter, typical	OD	mm	33,8	35,5	39,5	42,5	46,5
Fracture load, typical	F <sub>m</sub>	kN	120	120	140	160	200
Min. breaking capacity		kN	80	80	100	120	150
Recommended initial anchorage		kN	30 - 60			60 - 100	
Standard bar length	L	m	0,5 - 3,1			1,5 - 4,9	

## guide to coding system

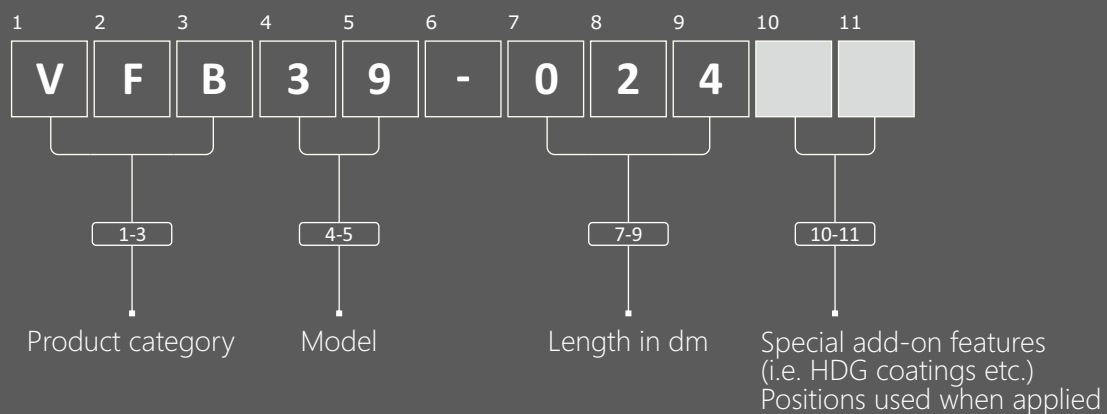

# ViDEX™ operation - installation

The ViDEX™ friction-bolt is percussively driven into a slightly smaller hole than the nominal diameter of the bolt. As the split-type tube is gradually sliding into the hole, it is forced to compress and simultaneously exerts radial forces to the surrounding ground.

Installation is finished when the total length of the split-type tube has entered the hole and when firm contact of the plate with the ground surface has been achieved. The split-type tube exerts now radial pressure against the rock over its full contact length while the washer plate provides load support of the lower section of the ground.

The developed frictional forces resist the sliding of the tube as well as the movement of the rock mass. The loading of the rock is instantaneous with completion of the ViDEX™ bolt installation, which usually lasts less than a minute. Instant anchoring is achieved offering IMMEDIATE SUPPORT.

The ViDEX™ friction-bolts can conform to changing ground conditions in contrast to conventional rock-bolts that "loosen". In the instance of ground movement the ViDEX™ friction-bolts can yield rather than fail. Due to this ability of conforming they are internationally known as "the intelligent" anchoring system.

Pull tests have shown that the superior supporting power of the split-type friction-bolts increases with time (in contrast with the ordinary rock-bolts that can loosen when ground shifts). Furthermore, research has shown that as the external surface of the tube corrodes, the holding power of the bolt increases.

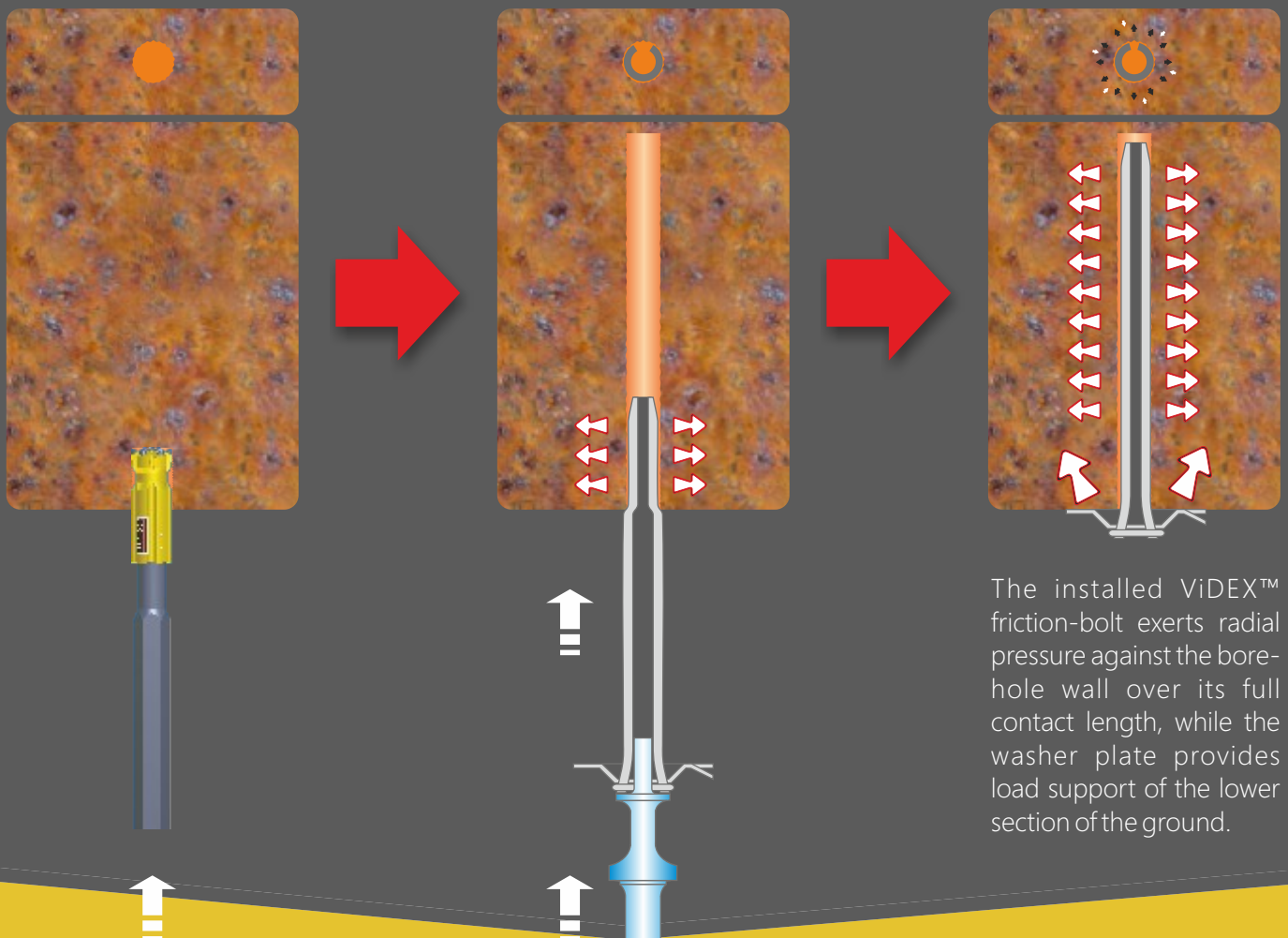

# ViDEX™ installation equipment

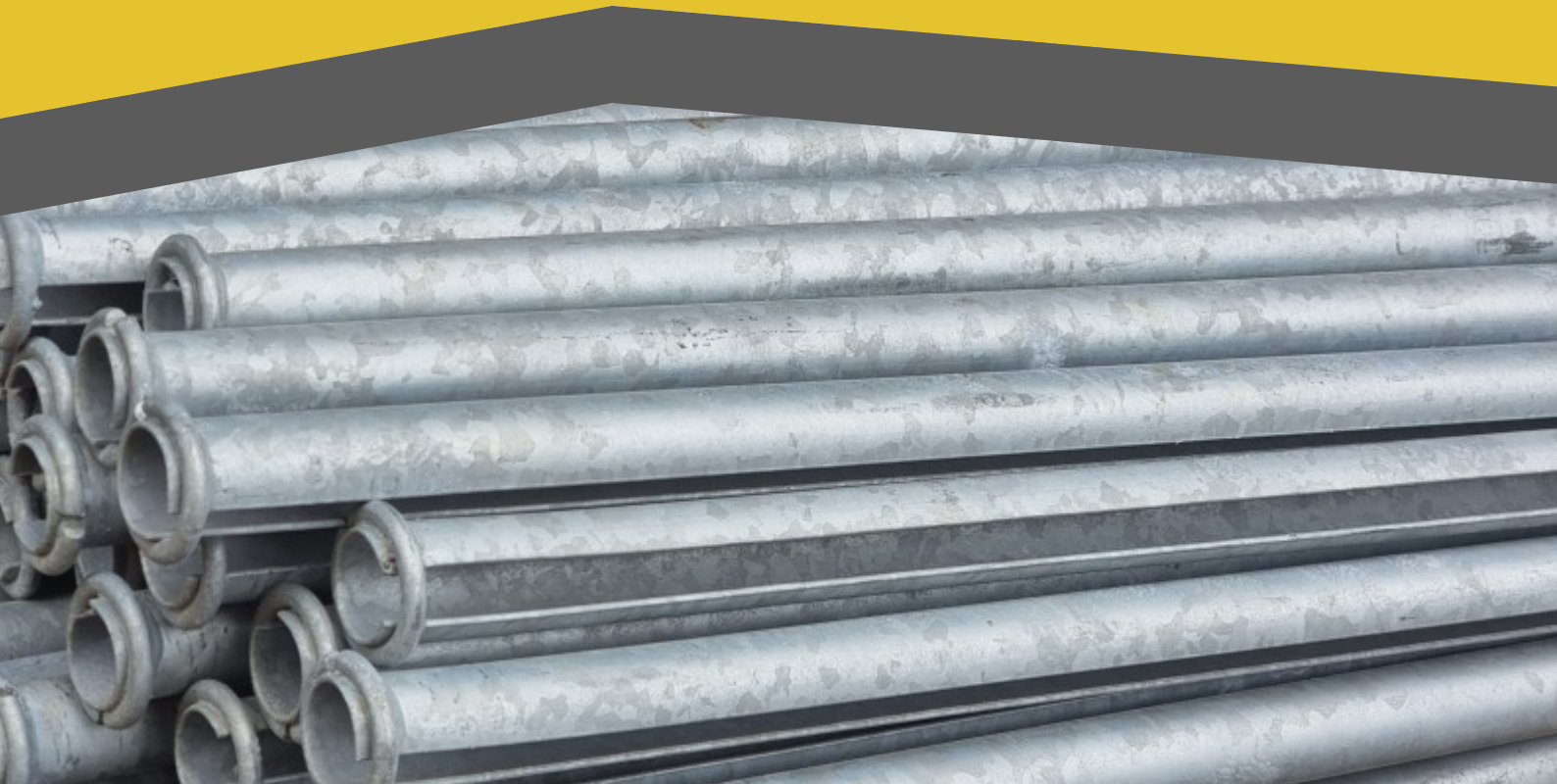

A variety of driver tools standard are available to suit installations with jag leg hammers or for mechanized installations with bolters or jumbos. Tools are manufactured from 42CrMo4 alloy steel subsequently case hardened for added durability. Entire range of the internationally standardized threads used in percussion-rotary drilling are available, such as R32, R38, T38, T45 and T51. Custom models can be manufactured upon demand.





# ViDEX™ pull-out testing equipment



Complete pull-out test system for ViDEX™ friction bolts is available comprised of a hollow hydraulic cylinder, a hydraulic pump, a manometer for monitoring the applied load, a cylinder resting base and suitable gripping device.

The system is available for sale or rental.

Newly designed gripping devices allow aligned exerted force during pull-testing, without uneven deformation of the bolt ring.

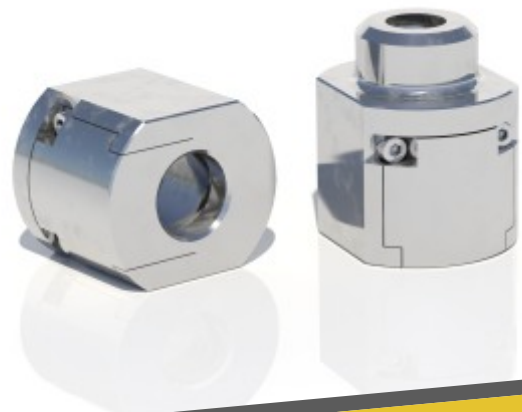



## ELEBOR S.A.

1 Pindou str. & 17 Poseidonos ave.,

GR-183 44 Moschato

Athens, Hellas

Tel.: +30 210 94 00 006

Fax: +30 210 94 00 566

e-mail: info@elebor.gr



[www.elebor.gr](http://www.elebor.gr)

